



Performance Under Pressure

PARTS LIST FOR
CW-2505-4MDY
CW-3004-4MDY
(AFTER SERIAL #10375000)

Engine Oil Grade:	SAE 20W-40
Engine Oil Capacity:	56 oz.
Pump Oil Grade:	Mi-T-M Pump Oil #AW-4085-0016
Pump Oil Capacity:	41 oz.
Nozzle Size:	
CW-2505:	5.5
CW-3004:	4.0

This Parts Listing has been compiled for your benefit. You can be assured your Mi-T-M Cold Water Pressure Washer was constructed and designed with quality and performance in mind using over 25 years experience in the pressure washer business. Each component has been rigorously tested to insure the highest level of acceptance.

The contents of this Parts Listing are based on the latest product information available at the time of publication. Mi-T-M reserves the right to make changes in price, color, materials, equipment, specifications or models at any time without notice.

WARNING

THIS IS A PROFESSIONAL HIGH PRESSURE, COLD WATER PRESSURE WASHER. CAUTION SHOULD BE OBSERVED WHEN USING OR REPAIRING THIS UNIT! READ AND FOLLOW THE SAFETY WARNINGS LISTED BELOW BEFORE ATTEMPTING ANY REPAIRS ON THIS PRESSURE WASHER!

SAFETY WARNINGS

1. NEVER alter or modify the equipment. Be sure any accessory items and system components being used will withstand the pressure developed. Use only genuine Mi-T-M parts for repair of your pressure washer. Failure to do so can cause hazardous operating conditions and will VOID warranty.
2. NEVER maintenance the unit while running. Using the engine stop lever turn the engine off, remove the key from the key switch. Turning over the machinery by hand during adjustment or cleaning might start the machinery, causing serious injury to the operator.
3. Know how to stop and bleed pressures quickly. Be thoroughly familiar with controls.
4. Before servicing the unit, turn unit off, relieve the water pressure and allow the unit to cool down. Do not make repairs while the unit is running. Service in a clean, dry, flat area.
5. After testing the machine, DO NOT leave the pressurized unit unattended. Shut off the unit and release trapped pressure before leaving.

Table of Contents

SPECIFICATIONS.....3

FRAME ASSEMBLY FOR CW-2505-4MDY4

FRAME ASSEMBLY FOR CW-3004-4MDY6

PUMP ASSEMBLY (3-0202) (AFTER SERIAL #10375000).....8

UNLOADER ASSEMBLY (8-0032)10

GUN ASSEMBLY (16-0001)12

NOTES14

SPECIFICATIONS

CW-2505/3004-4MDY

MODEL NUMBER	CW-2505-4MDY	CW-3004-4MDY
Operating Pressure (PSI/Bar):	2500/172.4	3000/206.8
High Pressure Nozzle:	5.5	4.0
Water Volume (GPM/lpm):	4.4/16.6	3.5/13.2
Engine:	Yanmar	
Horsepower	9.0	
Engine Type	Air Cooled, Vertical Single Cylinders, Four Stroke Diesel	
Oil Type	SAE20W-40	
Oil Capacity (oz./liters)	56/1.6	
Fuel Type	Diesel	
Fuel Capacity (gallon/ liters)	.95/3.6	
Starting	Recoil	
Maximum No Load RPM	3600 (+/- 100) RPM	
Pump:	Belt Driven, Oil Bath, Triplex Piston	
Oil Type	Mi-T-M Pump Oil #AW-4085-0016	
Oil Capacity (oz./liters)	41/1.2	
Plungers	Ceramic	
Manifold	Forged Brass	
Valves	Stainless Steel	
Unloader	Preset	
Heat Dump Valve	Relieves heated water during unloader bypass stage	
Unit Net Weight (lbs/Kg)	250/113	
Unit Shipping Weight (lbs/Kg)	321/145.5	
Unit Net Dimension (in/cm)	46Lx28Wx30H/117Lx71Wx76H	
Unit Shipping Dimension (in/cm)	48.5Lx30.5Wx35.5H/123Lx77.5Wx90H	

FRAME ASSEMBLY FOR CW-2505-4MDY

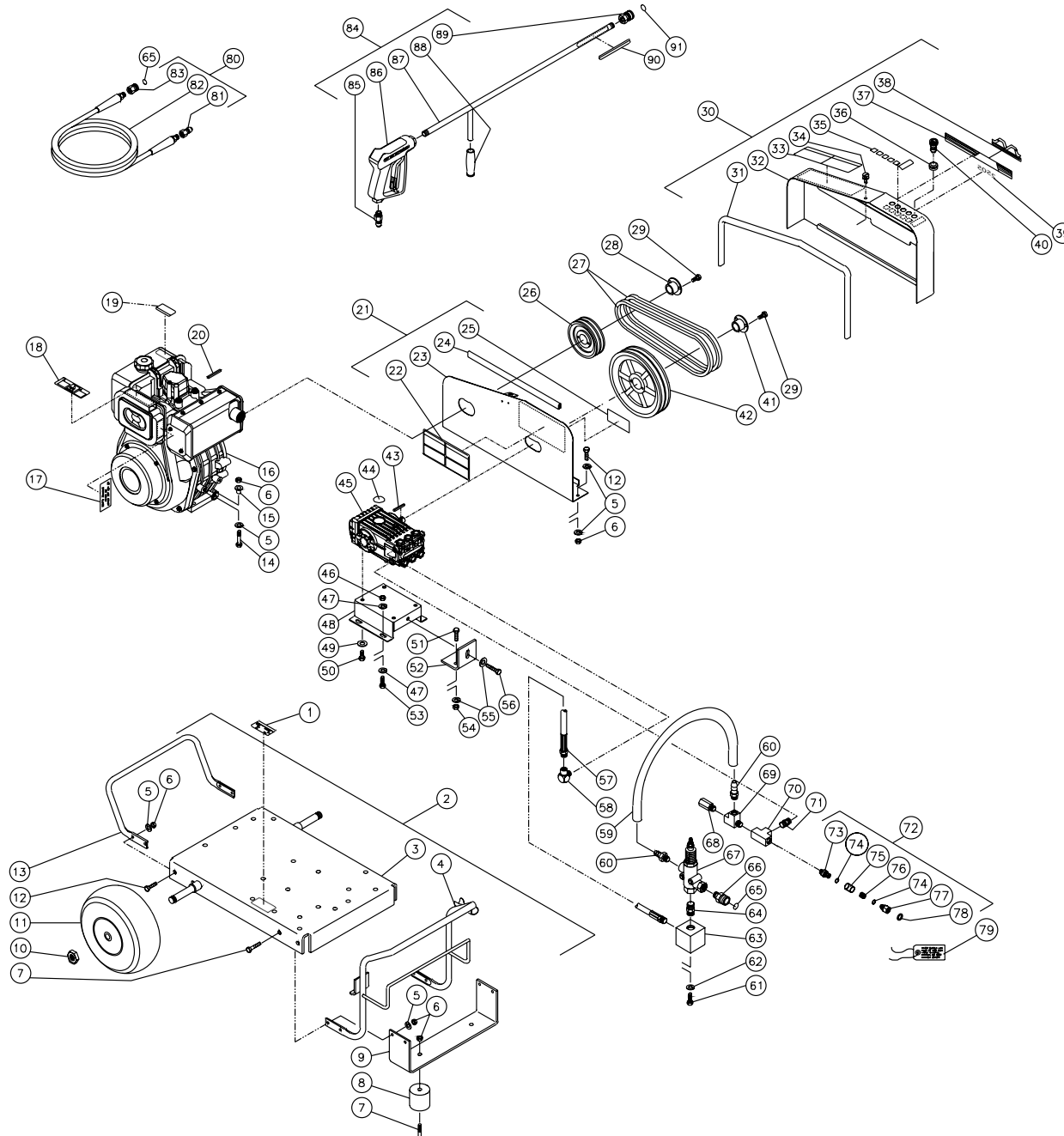

CW-2505-4MDY-090401-RD

FRAME ASSEMBLY FOR CW-2505-4MDY											
REF. #	DESCRIPTION	PART #	QTY.	REF. #	DESCRIPTION	PART #	QTY.	REF. #	DESCRIPTION	PART #	QTY.
1	Decal- Data Plate	N/A	1	33	Decal- Operating Instructions (E/S)	34-0813	1	62	Washer	29-0008	2
2	Base Plate Assembly (Inc. 3-13)	851-0270	1	34	Fastener	33-0197	1	63	Manifold Block	51-0012	1
3	Base Plate	5-0117A01	1	35	Nozzles	34-0500	1	64	Hex Nipple	24-0031	1
4	Handle- Front	7-0101A01	1	36	Grommet	33-0001	5	65	O-ring (Replacement Only)	25-0123	-
5	Washer	28-0003	20	37	Decal- Mi-T-M Stripe	34-0501	1	66	Quick Connect Socket	17-0029	1
6	Locknut	30-0157	18	38	Decal- Mi-T-M Logo	62-0086	1	67	Unloader	8-0032	1
7	Bolt	27-0068	6	39	Decal- Die Cut 2505	34-0416	1	68	Heat Dump Valve	22-0005	1
8	Isolator	14-0008	2	40	Spray Nozzle- 0005.5	18-0035	1	69	Tee	23-0124	1
9	Underbracket	13-0042A01	1	-	Spray Nozzle- 1505.5	18-0041	1	70	Tee	23-0043	1
10	Jamnut	30-0117	2	-	Spray Nozzle- 2505.5	18-0062	1	71	Hex Nipple	23-0012	1
11	Wheel	14-0006	2	-	Spray Nozzle- 4005.5	18-0132	1	72	Filter Assembly (Inc. 73-78)	19-0206	1
12	Bolt	27-0067	8	41	Bushing	9-0017	1	73	Filter Outlet-NPT (See 19-0206)	N/A Sep.	1
13	Handle- Rear	7-0104A01	1	42	Sheave	10-0040	1	74	O-Ring	25-0517	1
14	Bolt	27-0070	4	43	Key	43-0048	1	75	Sight Glass-Filter	19-0208	1
15	Engine Shim	33-0169	4	44	Decal- Pump ID Number	N/A	1	76	Screen-Strainer	19-0209	1
16	Engine- 9.0 HP	1-0084	1	45	Pump	3-0202	1	77	Filter Inlet-Garden Hose (See 19-0206)	N/A Sep.	1
17	Decal- Do Not Use Ether	34-0141	1	46	Locknut	30-0161	4	78	Garden Hose Gasket	26-0001	1
18	Decal- Warning: Muffler Hot (E/S)	34-0598	1	47	Washer	28-0030	8	79	Tag-Water Supply Inlet	34-0097	1
19	Decal- Caution: Allow to Cool (E/S)	34-0599	1	48	Pump Bracket	5-0101A01	1	80	High Pressure Hose Assembly (Inc. 81-83)	851-0007	1
20	Key	43-0078	1	49	Washer	29-0055	4	81	Quick Connect Plug	17-0006	1
21	Beltguard Back Assembly (Inc. 22-25)	851-0271	1	50	Bolt	27-8471	4	82	Pressure Hose	15-0003	1
22	Decal- Warning/Caution (E/S)	34-0812	1	51	Bolt	27-0118	2	83	Quick Connect Socket	17-0004	1
23	Decal- Warning: Beltguard Back (See 851-0271)	N/A Sep.	1	52	Brace Tightener	13-0003A01	1	84	Gun/Wand Assembly (Inc. 85-89)	851-0095	1
24	Edging *(Two Feet Required)	33-0020	1	53	Bolt	27-0166	4	85	Quick Connect Plug	17-0005	1
25	Decal- Beltguard Cover (E/S)	34-0826	1	54	Locknut	30-0159	2	86	Gun	16-0001	1
26	Sheave	10-0067	1	55	Washer	28-0023	3	87	Wand	16-0120A01	1
27	Belt:	11-0011	2	56	Bolt	27-0576	1	88	Handle Grip	7-0002	1
28	Bushing	9-0005	1	57	Hose	15-0024	1	89	Quick Connect Socket	17-0001	1
29	Bolt	27-0015	4	58	Elbow	24-0105	1	90	Decal- Warning: Risk of Injection (E/S)	34-1253	1
30	Beltguard Cover Assembly (Inc. 31-38)	851-0216	1	59	By-pass Hose	15-0035	1	91	O-ring (Replacement Only)	25-0122	-
31	Edging *(Four Feet Required)	33-0020	1	60	Hose Barb	23-0007	2	*Must Order in One Foot Lengths			
32	Beltguard Cover (See 851-0216)	N/A Sep.	1	61	Bolt	27-0116	2				

FRAME ASSEMBLY FOR CW-3004-4MDY

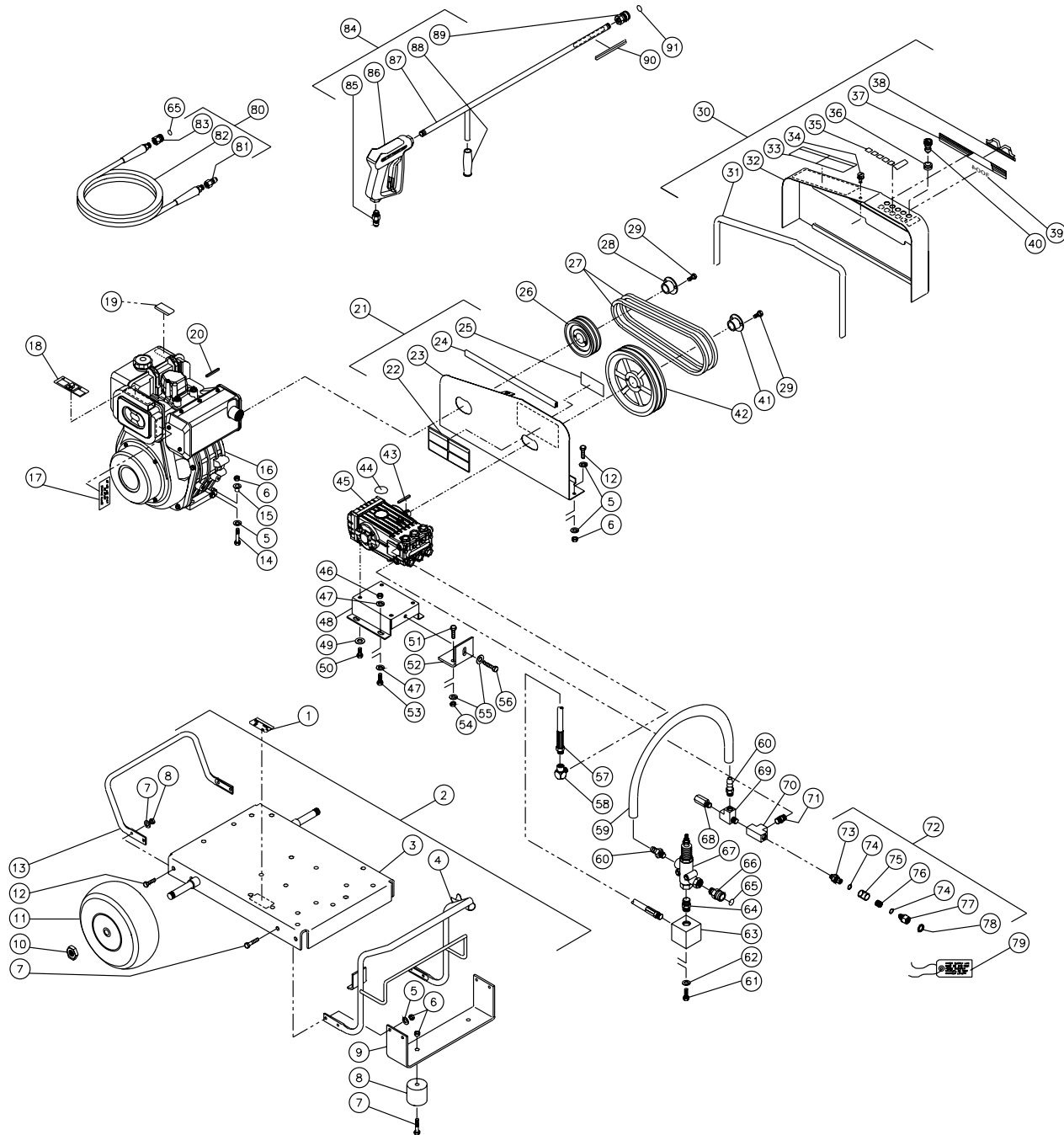

CW-3004-4MDY-090501-RD

FRAME ASSEMBLY FOR CW-3004-4MDY											
REF. #	DESCRIPTION	PART #	QTY.	REF. #	DESCRIPTION	PART #	QTY.	REF. #	DESCRIPTION	PART #	QTY.
1	Decal- Data Plate	N/A	1	33	Decal- Operating Instructions (E/S)	34-0813	1	62	Washer	29-0008	2
2	Base Plate Assembly (Inc. 3-13)	851-0270	1	34	Fastener	33-0197	1	63	Manifold Block	51-0012	1
3	Base Plate	5-0117A01	1	35	Nozzles	34-0500	1	64	Hex Nipple	24-0031	1
4	Handle- Front	7-0101A01	1	36	Grommet	33-0001	5	65	O-ring (Replacement Only)	25-0123	-
5	Washer	28-0003	20	37	Decal- Mi-T-M Stripe	34-0501	1	66	Quick Connect Socket	17-0029	1
6	Locknut	30-0157	18	38	Decal- Mi-T-M Logo	62-0086	1	67	Unloader	8-0032	1
7	Bolt	27-0068	6	39	Decal- Die Cut 3004	34-0105	1	68	Heat Dump Valve	22-0005	1
8	Isolator	14-0008	2	40	Spray Nozzle- 0004	18-0028	1	69	Tee	23-0124	1
9	Underbracket	13-0042A01	1	-	Spray Nozzle- 1504	18-0029	1	70	Tee	23-0043	1
10	Jamnut	30-0117	2	-	Spray Nozzle- 2504	18-0030	1	71	Hex Nipple	23-0012	1
11	Wheel	14-0006	2	-	Spray Nozzle- 4004	18-0031	1	72	Filter Assembly (Inc. 73-78)	19-0206	1
12	Bolt	27-0067	8	41	Bushing	9-0017	1	73	Filter Outlet-NPT (See 19-0206)	N/A Sep.	1
13	Handle- Rear	7-0104A01	1	42	Sheave	10-0040	1	74	O-Ring	25-0517	1
14	Bolt	27-0070	4	43	Key	43-0048	1	75	Sight Glass-Filter	19-0208	1
15	Engine Shim	33-0169	4	44	Decal- Pump ID Number	N/A	1	76	Screen-Strainer	19-0209	1
16	Engine- 9.0 HP	1-0084	1	45	Pump	3-0202	1	77	Filter Inlet-Garden Hose (See 19-0206)	N/A Sep.	1
17	Decal- Do Not Use Ether	34-0141	1	46	Locknut	30-0161	4	78	Garden Hose Gasket	26-0001	1
18	Decal- Warning: Muffler Hot E/S)	34-0598	1	47	Washer	28-0030	8	79	Tag-Water Supply Inlet	34-0097	1
19	Decal- Caution: Allow to Cool (E/S)	34-0599	1	48	Pump Bracket	5-0101A01	1	80	High Pressure Hose Assembly (Inc. 81-83)	851-0007	1
20	Key	43-0078	1	49	Washer	29-0055	4	81	Quick Connect Plug	17-0006	1
21	Beltguard Back Assembly (Inc. 22-25)	851-0271	1	50	Bolt	27-8471	4	82	Pressure Hose	15-0003	1
22	Decal- Warning/Caution (E/S)	34-0812	1	51	Bolt	27-0118	2	83	Quick Connect Socket	17-0004	1
23	Decal- Warning: Beltguard Back (See 851-0271)	N/A Sep.	1	52	Brace Tightener	13-0003A01	1	84	Gun/Wand Assembly (Inc. 85-89)	851-0095	1
24	Edging *(Two Feet Required)	33-0020	1	53	Bolt	27-0166	4	85	Quick Connect Plug	17-0005	1
25	Decal- Beltguard Cover (E/S)	34-0826	1	54	Locknut	30-0159	2	86	Gun	16-0001	1
26	Sheave	10-0029	1	55	Washer	28-0023	3	87	Wand	16-0120A01	1
27	Belt:	11-0036	2	56	Bolt	27-0576	1	88	Handle Grip	7-0002	1
28	Bushing	9-0005	1	57	Hose	15-0024	1	89	Quick Connect Socket	17-0001	1
29	Bolt	27-0015	4	58	Elbow	24-0105	1	90	Decal- Warning: Risk of Injection (E/S)	34-1253	1
30	Beltguard Cover Assembly (Inc. 31-38)	851-0216	1	59	By-pass Hose	15-0035	1	91	O-ring (Replacement Only)	25-0122	-
31	Edging *(Four Feet Required)	33-0020	1	60	Hose Barb	23-0007	2	*Must Order in One Foot Lengths			
32	Beltguard Cover (See 851-0216)	N/A Sep.	1	61	Bolt	27-0116	2				

PUMP ASSEMBLY (3-0202) (AFTER SERIAL #10375000)

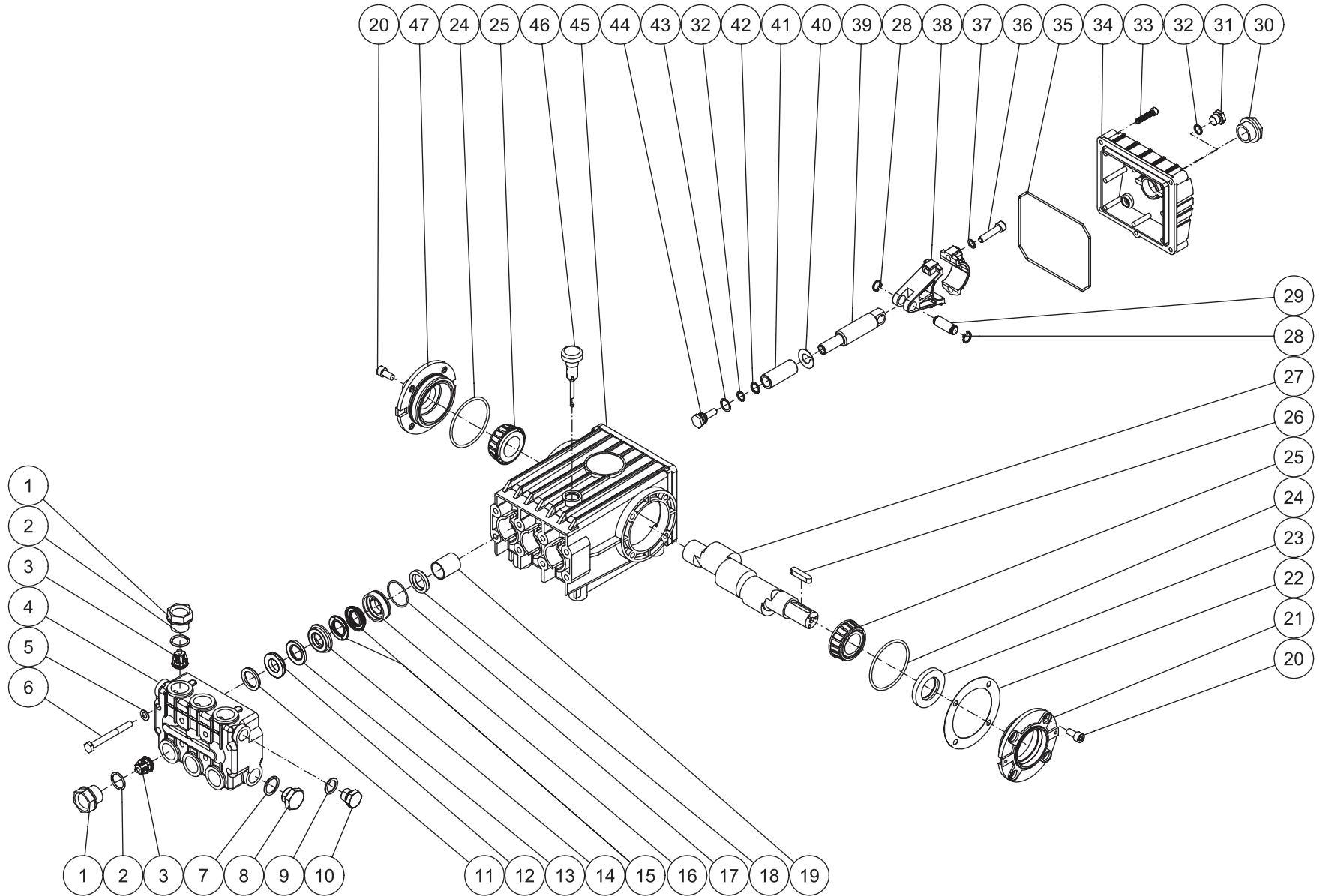

3-0202_3-0203-010408-JJT

PUMP ASSEMBLY											
REF. #	DESCRIPTION	PART #	QTY.	REF. #	DESCRIPTION	PART #	QTY.	REF. #	DESCRIPTION	PART #	QTY.
1	Valve Plug	46-0889	6	18	Oil Seal	26-0047	3	35	O-ring Cover	25-0339	1
2	O-ring	25-0012	6	19	Bushing	9-0029	3	36	Bolt	27-8435	6
3	Valve Assembly (See 70-0009)	N/A Sep.	6	20	Bolt	27-8431	8	37	Lockwasher	29-0154	6
4	Manifold	46-0890	1	21	Crankcase Open Cover	46-0296	1	38	Connecting Rod	46-0051	3
5	Flatwasher	28-1039	8	22	Shim	46-0113	1	39	Piston Rod	46-0056	3
6	Bolt	27-8185	8	23	Oil Seal	26-0049	1	40	Washer	46-0146	3
7	Washer	28-1038	2	24	O-ring	25-0013	2	41	Plunger	46-0052	3
8	Plug	39-0019	2	25	Bearing	48-0012	2	42	Back-up Ring	46-0109	3
9	Washer	28-1002	2	26	Key	43-0048	1	43	Washer	28-0400	3
10	Plug	39-0018	2	27	Crankshaft	N/A	1	44	Bolt	46-0069	3
11	O-ring (See 70-0030)	N/A Sep.	3	28	Retaining Ring	46-0103	6	45	Crankcase	46-0047	1
12	V-Packing	26-0098	3	29	Connecting Rod Pin	43-0032	3	46	Oil Dip Stick	46-0144	1
13	Ring	25-0207	3	30	Oil Level Indicator	46-0114	1	47	Crankcase Cover	46-0336	1
14	High Pressure Intermediate Seal Retainer	46-0659	3	31	Plug	39-0017	1		Valve Kit (6 each 3)	70-0009	
15	Low Pressure Seal	N/A Sep.	3	32	O-ring	25-0014	4		Head Ring Kit (1 each 11)	70-0030	
16	Low Pressure Seal Retainer	46-0057	3	33	Bolt	27-8404	5		V-Packing Kit (3 each 12, 13, 15)	70-0147	
17	O-ring	25-0015	3	34	Crankcase Cover	46-0295	1		Intermediate Retainer Kit (3 each 13, 14)	70-0148	
									V-Packing Assembly (3 each 11-17)	852-0122	

UNLOADER ASSEMBLY (8-0032)

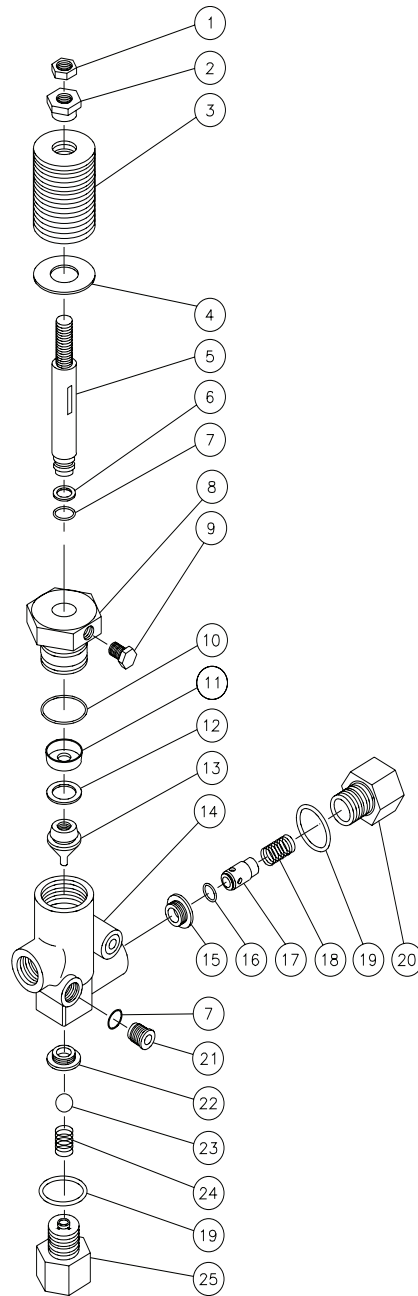

OMGEN074-083094-BAR

UNLOADER ASSEMBLY (8-0032)			
REF.#	DESCRIPTION	PART #	QTY.
1	Locknut	30-3058	1
2	Adjusting Nut	8-0089	1
3	Spring Washers - Orange	8-0009	15
4	Washer	28-0250	1
5	Valve Stem	8-0037	1
6	Backup Ring	8-0038	1
7	O-ring	25-0009	5
8	Valve Cap	8-0036	1
9	Set Screw	8-0084	1
10	O-ring	25-0008	1
11	Cup	8-0034	1
12	Back-up Ring	8-0040	1
13	Piston	8-0039	1
14	Valve Body	8-0164	1
15	Outlet Seat	8-0006	1
16	O-ring	25-0011	1
17	Outlet Valve	8-0004	1
18	Spring	49-0016	1
19	O-ring	25-0010	2
20	Outlet Retainer	8-0003	1
21	Brass Plug	8-0011	4
22	Valve Seat	8-0005	1
23	Ball	8-0041	1
24	Spring	49-0015	1
25	Inlet Retainer	8-0165	1
	Unloader Repair Kit (Inc. 6, 7, 10-12, 16 and 19)	70-0044	

GUN ASSEMBLY (16-0001)

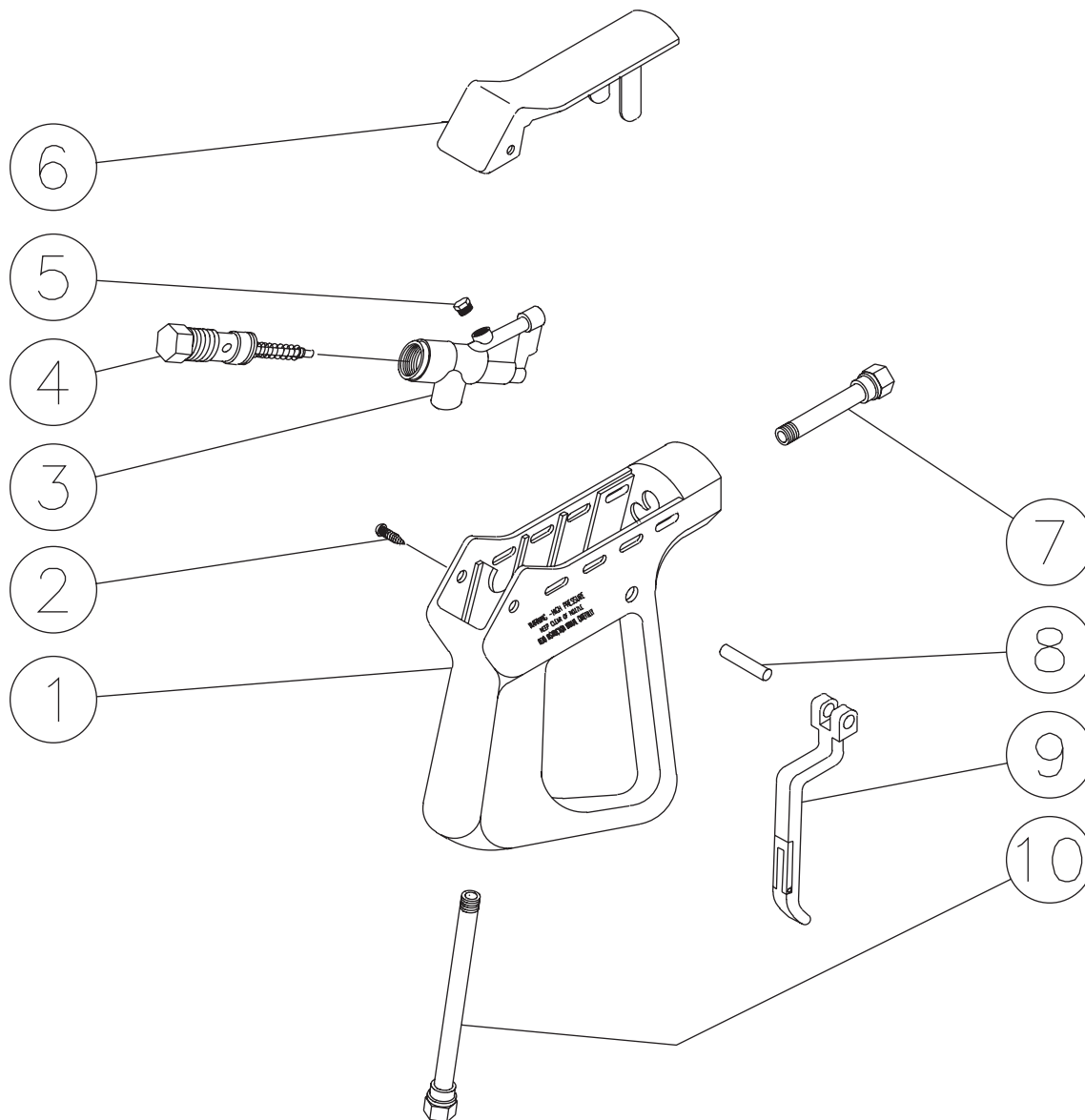

GUN ASSEMBLY (16-0001)			
REF. #	DESCRIPTION	PART #	QTY.
1	Plastic Housing	16-0008	1
2	Screw	27-3230	2
3	Brass Housing	16-0012	1
4	Gun Repair Kit	70-0055	1
5	Brass Plug	39-0024	1
6	Plastic Cover	16-0009	1
7	Pipe Assembly	16-0013	1
8	Trigger Pin	16-0063	1
9	Trigger/Safety Lock-off	16-0010	1
10	Pipe Assembly- Inlet	16-0016	1
	Complete Gun Assembly	16-0001	1

NOTES

NOTES

Manufactured by Mi-T-M
8650 Enterprise Drive, Peosta IA 52068
563-556-7484/ Fax 563-556-1235